

V-710SS

Overview

The V-710SS provides dependable one-shot feeding and batch count feeding of a wide variety of products. Ideal for collating and mail inserting applications that operate at speeds up to 100 cycles per minute. Simple tool-less adjustments for quick setups and changeovers.

Features

- Minimum Adjustment Points - 4 adjustment points for product changeover. Single knob adjustment.
- Thick Product Capability - Feed products that are .003" -.75" thick.
- Variable Angle Feed Belts - Enhanced feeder performance.
- Light Weight Construction - Portable.

Applications

- Collating
- Batch Counting
- Accumulating
- Kit Fulfillment
- Package Inserting
- Automatic Wrapping

Benefits

- Backer Board
- Booklets
- Brochures
- Cardstock
- Collapsed Cartons
- Envelopes
- Folded Documents
- Folders
- Literature
- Manuals
- Retail Signage
- Sheet Paper

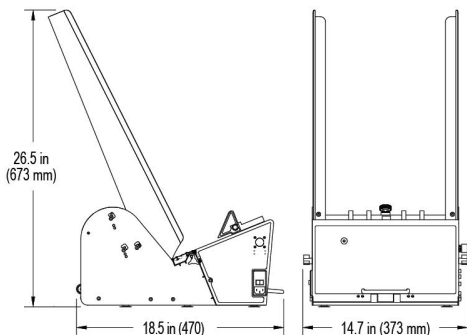

Specifications

Maximum Product Size
12 W x 12 L in (305 x 305 mm)*

Minimum Product Size
3.75 W x 3.75 L in (95 x 95 mm)*

Min/Max Product Thickness
.003 -.75 in (.076-19 mm)

Belt Speed
4000 in/min (101,600 mm/min)

Batch Size
1-50 pieces

Electrical Requirements
115/230vac, 50/60Hz, 3A

Weight
43 lbs. (19.5kg)

Warranty
One year limited

*Optional product size available

HAYSSEN | STREAMFEEDER | SYMACH | THIELE